

# FRANKLIN AVENUE BRIDGE

The Franklin Avenue Bridge, with its Gothic design motifs and turreted towers, is commonly called the Shakespeare Bridge. The design motif of the lancet arch is repeated in the balustrade and spandrel arches. The bridge was built to connect the Franklin Hills Area to East Hollywood and the Ivanhoe District.

## Seismic Retrofit

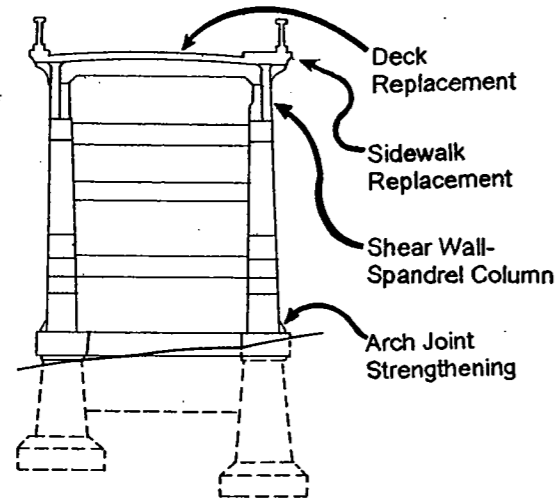

During the seismic retrofit the bridge deck was removed and the concrete ribs of the parabolic arch strengthened. The deck was replaced as a monolithic slab, eliminating the expansion joints.

Seismic Retrofit Legend	
	Deck Replacement
	Sidewalk Replacement
	Arch Joint Strengthening
	Shear Wall - Spandrel Columns
	Column Replacement
	Crack and Spall Repair

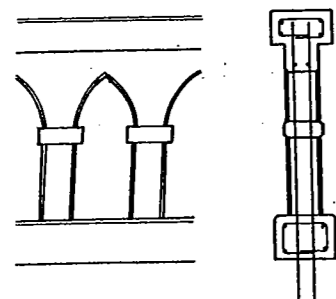
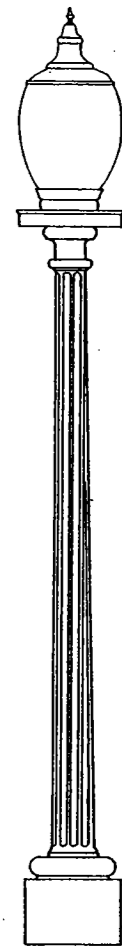
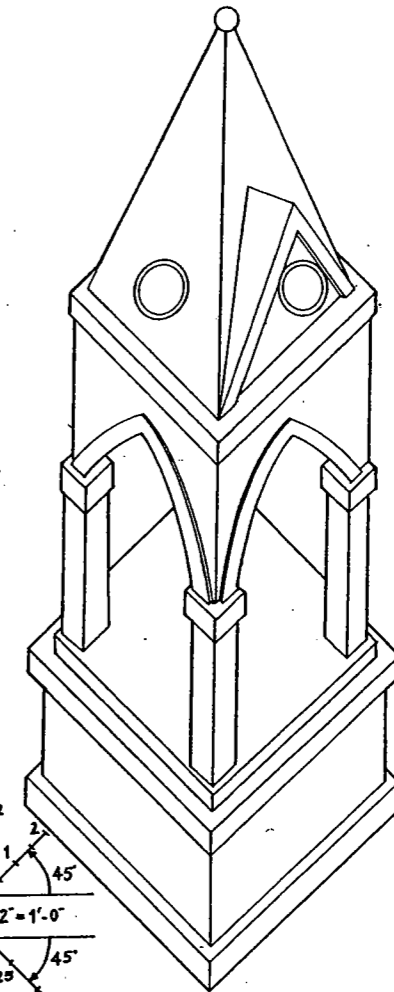
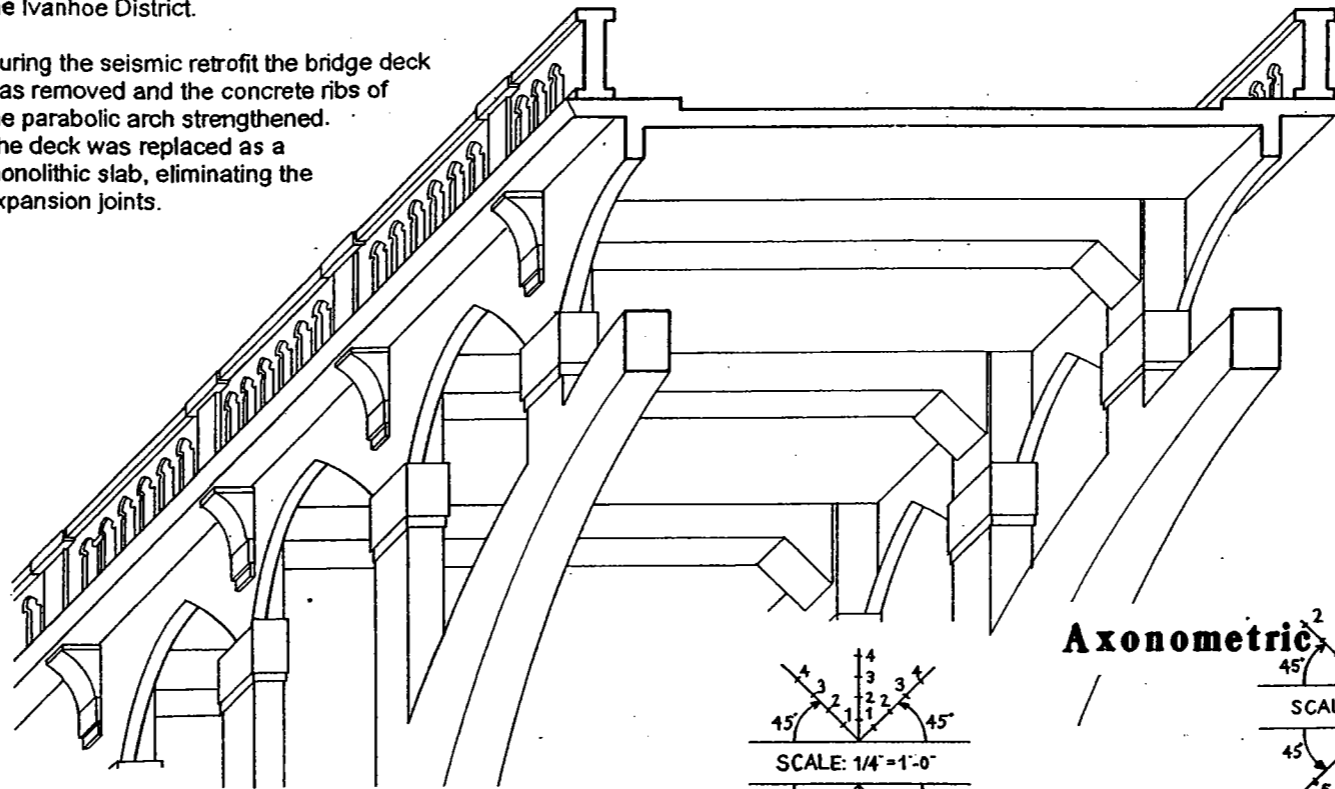

## Handrail Restoration

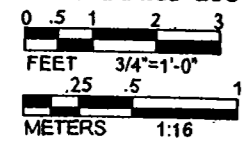

The existing handrails with pierced lancet arches were removed and restored to their original design.

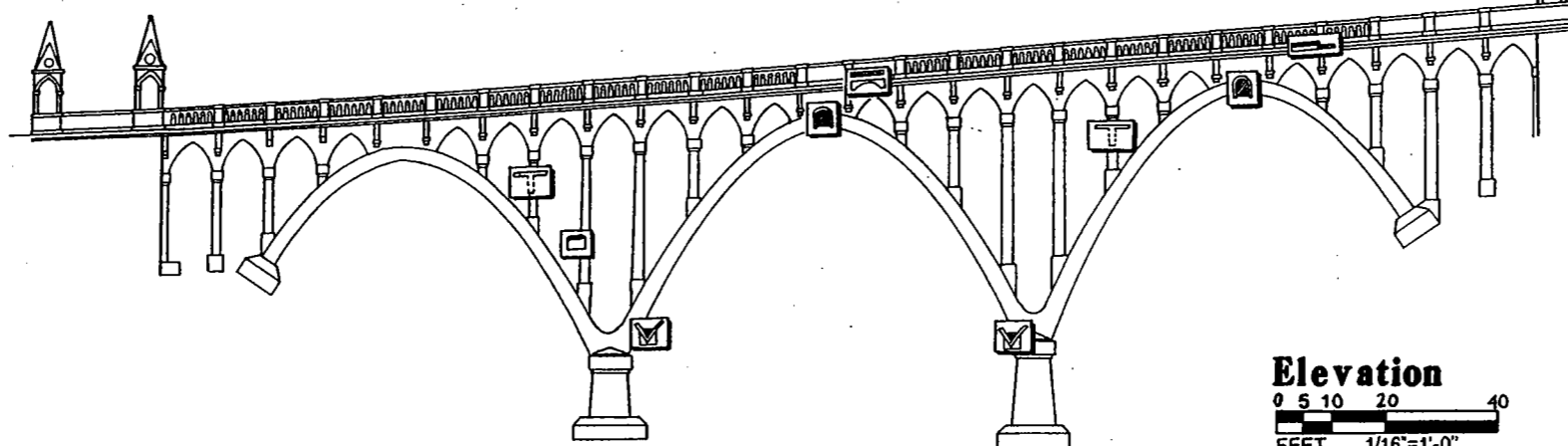

## Ornamental Tower

## Lamppost

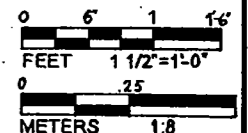

Original lampposts, light fixtures, towers and turrets were preserved and restored during the retrofit.

