

**CASE 1
SADDLE CONNECTION**

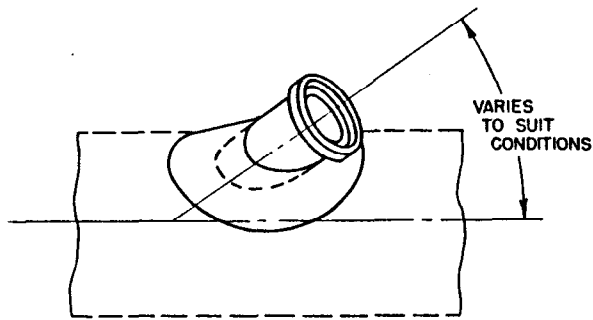

PLAN

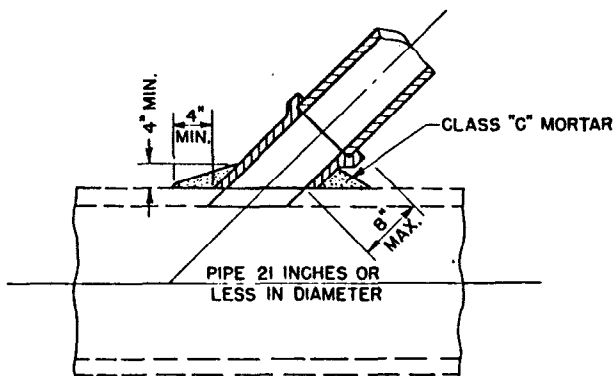

SECTION

**CASE 2
PIPE CONNECTION THROUGH BARREL**

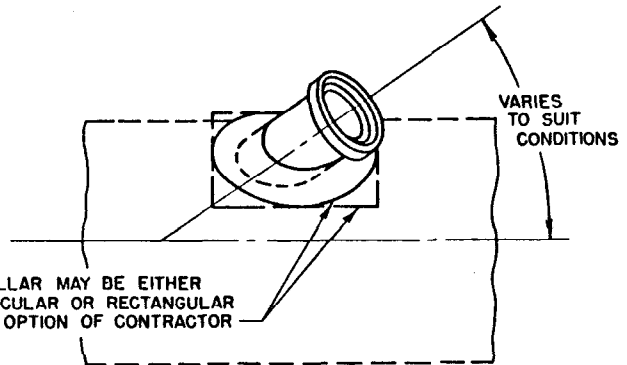

PLAN

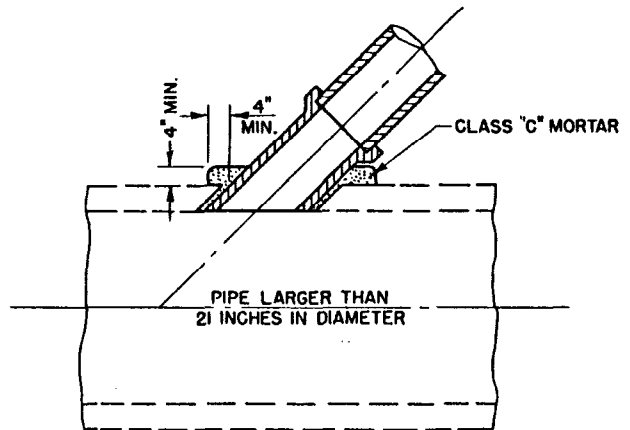

SECTION

- 1- CONNECTIONS TO PIPES 21 INCHES OR LESS IN DIAMETER WITHOUT JUNCTION STRUCTURES OR PRECAST Y BRANCHES SHALL BE MADE WITH SADDLES.
- 2- THE LENGTH OF THE SADDLE PIPE ON THE SHORT SIDE SHALL BE NOT MORE THAN 8 INCHES INCLUDING THE SOCKET.
- 3- THE SADDLE SHALL BE TRIMMED OR CUT SO THAT IT WILL FIT SNUGLY OVER THE OUTSIDE OF THE MAIN PIPE, AND SO THAT WHEN IN PLACE, ITS AXIS WILL BE ON THE LINE AND GRADE OF THE CONNECTING PIPE.
- 4- THE OPENING INTO THE PIPE SHALL BE CUT AND TRIMMED TO FIT THE SADDLE SO THAT NO PART WILL PROJECT WITHIN THE BORE OF THE SADDLE PIPE.
- 5- THE JOINT BETWEEN THE SADDLE AND THE MAIN PIPE SHALL BE COVERED WITH CLASS "C" MORTAR.
- 6- THE SADDLE AND CONNECTING PIPE SHALL BE SUPPORTED ACROSS THE OPEN SPACE BETWEEN THE MAIN LINE PIPE AND THE SIDE OF THE EXCAVATION IN ACCORDANCE WITH THE STANDARD PLAN FOR STANDARD METHODS OF SUPPORTING STORM DRAIN AND SEWER PIPES ACROSS TRENCHES.

- 1- CONNECTIONS TO PIPES OR CONDUITS LARGER THAN 21 INCHES IN DIAMETER WITHOUT JUNCTION STRUCTURES SHALL BE MADE THROUGH THE BARREL.
- 2- THE JOINT SHALL BE FINISHED SMOOTH ON THE INSIDE AND AT THE SAME TIME SHALL BE SURROUNDED ON THE OUTSIDE WITH A COLLAR OF CLASS "C" MORTAR NOT LESS THAN 4 INCHES BY 4 INCHES IN CROSS SECTION.
- 3- THE CONNECTING PIPE SHALL BE SUPPORTED ACROSS THE OPEN SPACE BETWEEN THE MAIN LINE PIPE AND THE SIDE OF THE EXCAVATION IN ACCORDANCE WITH THE STANDARD PLAN FOR STANDARD METHODS OF SUPPORTING STORM DRAIN AND SEWER PIPES ACROSS TRENCHES.

DEPARTMENT OF PUBLIC WORKS
BUREAU OF ENGINEERING CITY OF LOS ANGELES

**SPUR PIPE CONNECTIONS AND SADDLES
FOR STORM DRAINS**

STANDARD PLAN

B-3334

DESIGNED BY
F.E.C.
DRAWN BY
H.C.W.
CHECKED BY
F.E.CLOVE

SUBMITTED *April 6, 1950*

APPROVED *April 7, 1950*

BY *L.M. Armstrong*
ENGINEER - STORM DRAIN DESIGN

Ed. Adair
ENGINEER